

# PANELLER

# KAPILAR

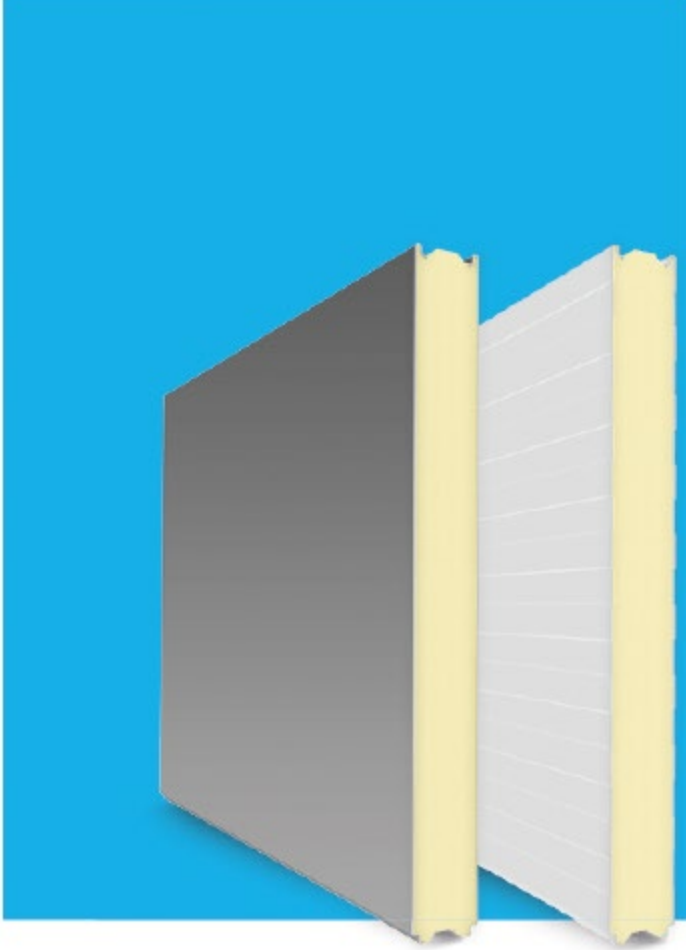

Oluklu Panel.....	10
Düz Panel.....	10

Çift Kanatlı Çarpma Soğuk Oda Kapısı.....	16
Tek Kanatlı Çarpma Soğuk Oda Kapısı.....	16
Ofis Kapısı.....	17
Monoraylı Menteşeli Kapı.....	18
Monoraylı Sürgülü Kapı.....	18
Sürgülü Kapı.....	19
Çift Kanatlı Flip-Flap Kapılar.....	20
Tek Kanatlı Flip-Flap Kapılar.....	20

# SOĞUTMA GRUPLARI

# UYGULAMA ALANLARI



Split Soğutma Cihazları.....	22
Endüstriyel Tip Kondenser Üniteler.....	23
Çift Üfleli Evaporatörler.....	25
Köşe Tavan Tipi Evaporatörler.....	26
Standart Evaporatörler.....	27
Şok Evaporatörler.....	28

Uygulama Alanları.....	30
Projeler.....	36
Uygulamalar.....	38

# SANDVIÇ PANELLER

## OLUKLU PANEL CORRUGATED PANEL

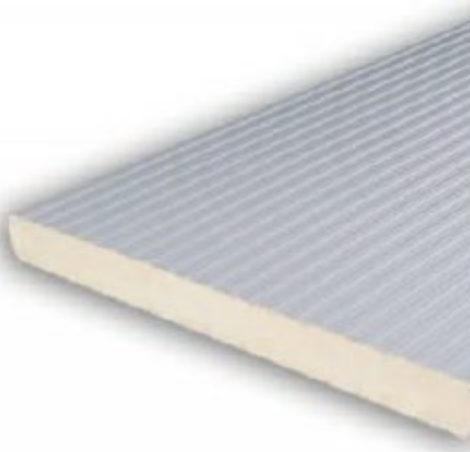

Standart üretimimiz üst yüzeyi 10 mm kalınlığında Plywood, alt yüzeyi galvaniz sac arası 40 (+/-2) dansite poliüretan enjekte edilmiş kilitli panellerdir. Oluklu zemin panelleri, duvar/tavan panelleri ile aynı, 7 farklı kalınlıktadır. Oluklu paneller 2000 kg/m<sup>2</sup> yayılı yük taşıma kapasiteli olup, ayrıca isteğe bağlı olarak yüzeyde plywood üzerine kaymaz CrNi veya 200 mikron PVC kaplı sac kullanılabilir.

Our standard production consists of 40 (+/- 2) density polyurethane injected locked panels of which the top surface is 10 mm thick plywood and bottom surface is galvanized sheet. Ribbed surface panels come in 7 different thicknesses, same as in the case of wall / ceiling panels. Ribbed panels have a load capacity of 2,000 kg/m<sup>2</sup> and non-slip CrNi or 200-micron PVC coated steel sheet can optionally be used on top of the plywood.

## DÜZ PANEL FLAT PANEL

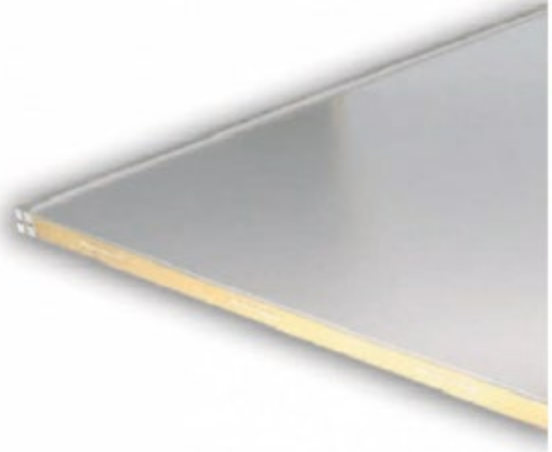

Endüstriyel soğuk depo paneli ile aynı özellikte olan bu panel, yüzeyindeki olukların olmayışından dolayı daha hijyenik bir ortam oluşturmakta kullanılmaktadır.

This panel, which has the same specifications as the industrial cold warehouse panel, is used to create a more hygienic environment due to the fact that it is not ribbed on its surface.

- Soğuk depolarda kullanılan poliüretan sandviç panel uygulamalarında, teknik, nitelik ve ısı izolasyon açısından ALBA soğuk depo panelleri mükemmel sonuç veren ideal bir üründür.

- Proje ölçülerinize göre özel imalat yapılmaktadır.

- Panellerimiz dış ortamda çalışabilmekte olup betonarme veya çelik yapı çatı altına herhangi bir ikinci dış duvara gerek duymadan kurulum yapılabilir.

- Polyurethane sandwich panels used in cold storage applications, technical, quality and ALBA cold room panels are the ideal product with excellent results.

- Custom manufacturing is done according to your project size.

- Our panel is able to work outdoors under concrete or steel structure roof installation without the need of any second outer wall can be made.

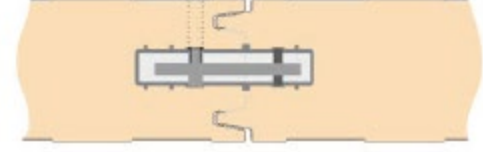

*Birleşim Detayı*  
*Connection Detail*

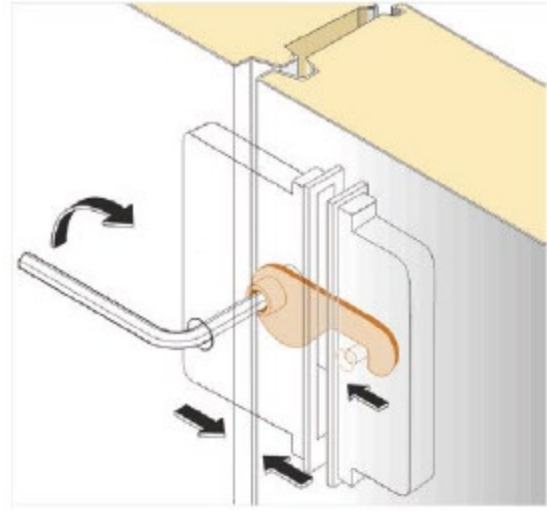

*Kilit Detayı*  
*Lock Details*

## YÜK TAŞIMA TABLOSU LOAD CARRYING CAPACITY TABLE

Panel Kalınlığı (mm) Panel Thickness (mm)	Mesnet açıklığı (m) / Base width (m)												
	2.0	2.5	3.0	3.5	4.0	4.5	5.0	5.5	6.0	6.5	7.0	7.5	8.0
200	515	344	344	294	257	227	207	185	167	141	122	108	92
150	386	258	258	222	196	170	155	139	116	107	93	81	
120	312	202	202	188	153	138	124	114	100	86	73		
100	258	170	170	149	129	114	103	93	83	72			
80	206	139	139	118	103	93	83	77	65				
60	155	103	103	88	77	70	61	57					

# SANDVIÇ PANELLER

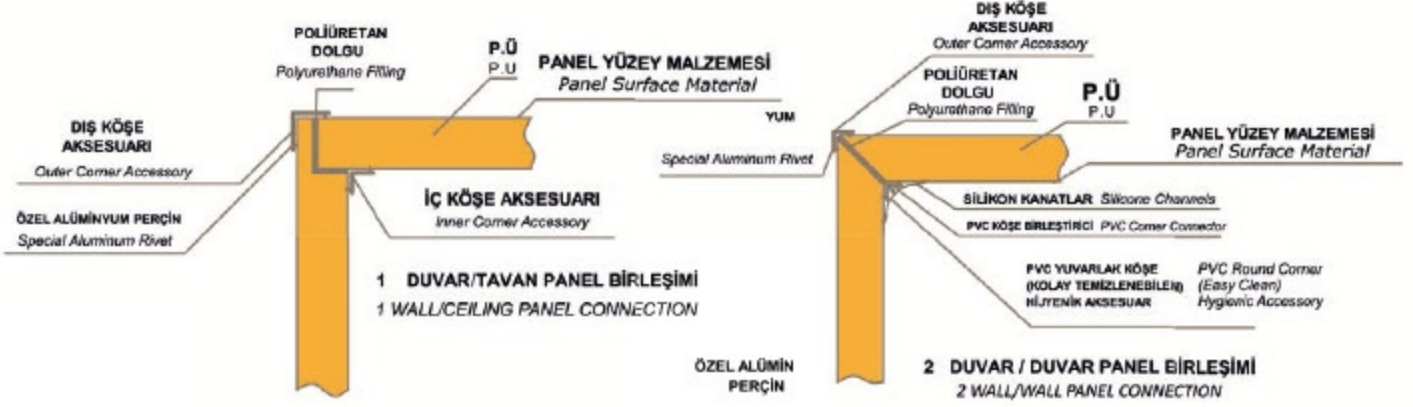

### 3 D.F. VE S.O. FARKLI YÜKSEKLİK DUVAR /TAVAN PANEL BİRLEŞİMİ

3 D.F. AND S.O. DIFFERENT HEIGHT WALL-CEILING PANEL CONNECTION

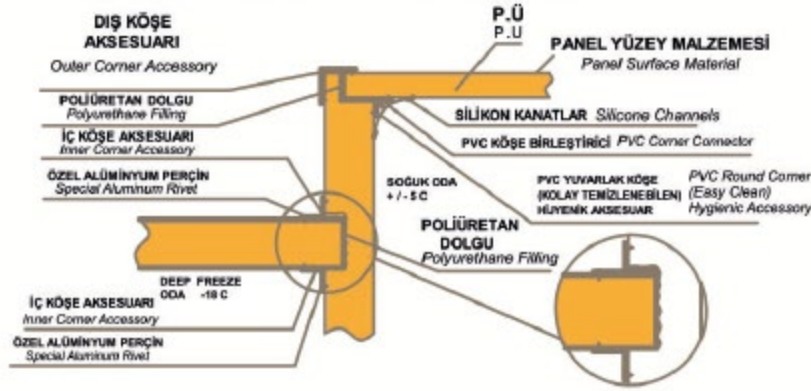

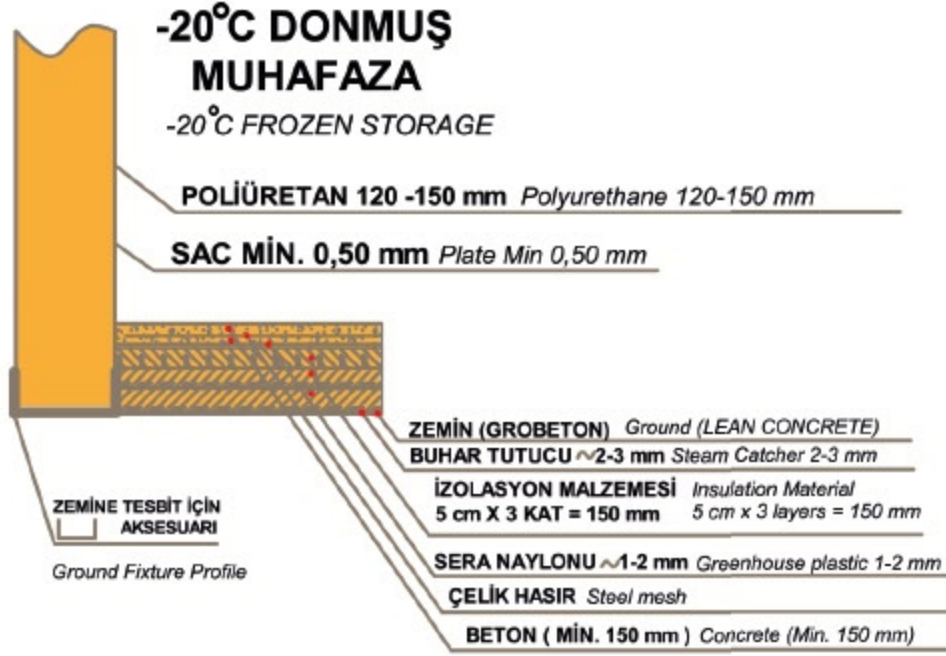

#### 4 TAVAN PANEL ASKI BİRLEŞİMİ

CEILING PANEL SUSPENSION CONNECTION

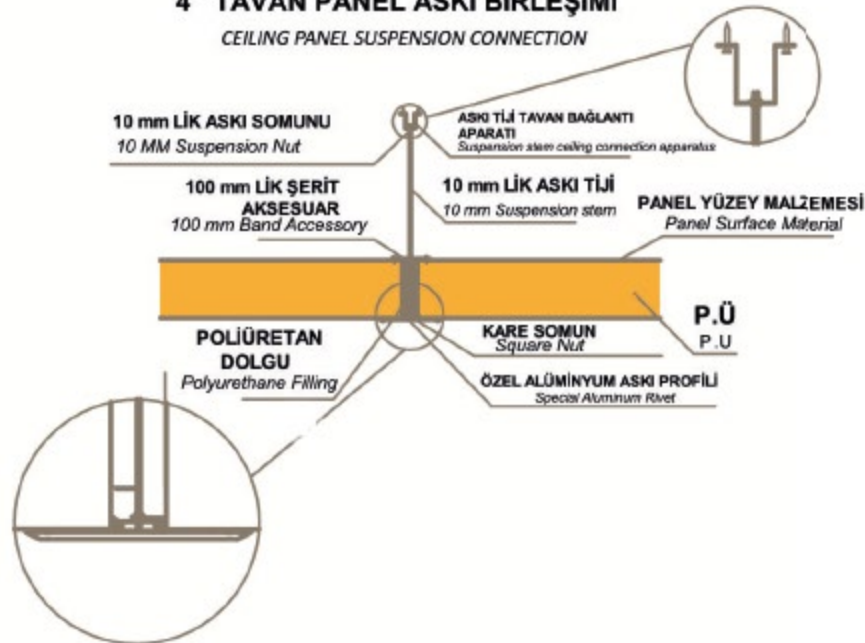

# SANDVIÇ PANELLER







### ÇİFT KANATLI ÇARPMA SOĞUK ODA KAPISI

DOUBLE WINGED MULTIPLICATION  
COLD ROOM DOOR



Soğuk ve donuk muhafaza odalarında kullanılır. Nitelikli ve ayrıcalıklı bir üründür. Sürgülü kapı uygulaması gerektiren, fakat yeterince alan bulunmayan odalarda kullanılır.

Çeşitli ebatlarda üretimi yapılabilir.

Used in cold and dull storage rooms. It is a qualified and privileged product. It is used in rooms that require sliding door application but not enough space.

It can be produced in various sizes.

### TEK KANATLI ÇARPMA SOĞUK ODA KAPISI

SOLID WING COLD ROOM DOOR



Soğuk ve donuk muhafaza odalarında kullanılır. Komple tek parça metal sac ile üretildiği için oldukça hijyenik ve şık bir üründür. Çarpma kilit olduğundan hızlı açılıp kapanabilen soğuk ve donuk muhafaza odası kapılarıdır. 90 x 190 cm ebatlarında üretilir. Özel tasarım ve çeşitli ebatlarda da üretilebilmektedir.

Used in cold and dull storage rooms. The assembly is made of one piece metal sheet, so it is very hygienic and elegant. The doors are cold and dull storage rooms that can be opened and closed quickly due to impact. It is produced in dimensions of 90 x 190 cm.

Special design and various sizes can be produced.

### OFİS KAPISI OFFICE DOOR



Şık, kullanışlı ve uzun ömürlü kullanım için, işletme içi serin odalar, soğutulmayan mahaller, işletme geçişleri, depo veya ofis kapısı olarak kullanılır. Çeşitli ebatlarda üretimi yapılabilir.

For cool, convenient and long-lasting use, it is used as in-house cool rooms, non-refrigerated spaces, business transits, warehouses or office doors. It can be produced in various sizes.



### MONORAYLI MENTEŞELİ KAPI MONORAIL HINGED DOOR



Monoray hatları ile birbirine bağlanan işleme ve depolama alanları için geçiş kapısı olarak kullanılır. Sağa veya sola tek kanat şeklinde çalışmaktadır. 90 x 190 cm veya çeşitli ebatlarda üretimi yapılabilir.

It is used as a gate for processing and storage areas connected by monorail lines. It works as a single wing to the right or left. It can be produced in 90 x 190 cm or various sizes.

### MONORAYLI SÜRGÜLÜ KAPI MONORAIL SLIDING DOOR



Monoray hatları ile birbirine bağlanan işleme ve depolama alanları için geçiş kapısı olarak kullanılır. Sağa veya sola sürgülü tek kanat şeklinde çalışmaktadır. Çeşitli ebatlarda üretimi yapılabilir.

It is used as a gate for processing and storage areas connected by monorail lines. It works as a single wing sliding right or left. It can be produced in various sizes.

# SÜRGÜLÜ KAPILAR

## SÜRGÜLÜ KAPI OFFICE DOOR



Sağa veya sola geniş aralıklarda açılabilen raylı kapılardır. Soğuk veya donuk muhafaza odalarında kullanılır. Çeşitli ebatlarda üretimi yapılabilir.

They are railing doors that can be opened wide to the right or to the left. Used in cold or dull storage rooms. It can be produced in various sizes.



### ÇİFT KANAT FLIP-FLAP KAPILAR DOUBLE WING FLIP-FLAP DOOR



Muhafaza alanları arası hızlı geçiş için kullanılır. Çift kanatlı, panele veya duvara monte edilebilir şekilde üretilir. Kanat, 40mm kalınlığında olup her iki yönde 180 derece açılabilir ve gerektiğinde daima açık kalabilir.

Used for fast switching between enclosure areas. It is produced with double wing, panel or wall mountable. The wing is 40mm thick and can be opened 180 degrees in both directions and can always stay open when needed.

### TEK KANAT FLIP-FLAP KAPILAR SINGLE WING FLIP-FLAP DOOR



Sağ veya sola geniş aralıklarda açılabilen raylı kapılardır. Soğuk veya donuk muhafaza odalarında kullanılır. Çeşitli ebatlarda üretimi yapılabilir.

They are railing doors that can be opened wide to the right or to the left. Used in cold or dull storage rooms. It can be produced in various sizes.

## FLIP-FLAP KAPILAR



## SPLIT SOĞUTMA CİHAZLARI SPLIT REFRIGERATION SYSTEMS

Soğuk ve donmuş muhafaza odaları şartlarına uygun olarak üretilir. Avrupa Birliği normlarına uygun olup CE markalı olarak imal edilir.

Produced in conformity with cold and frozen room conditions.

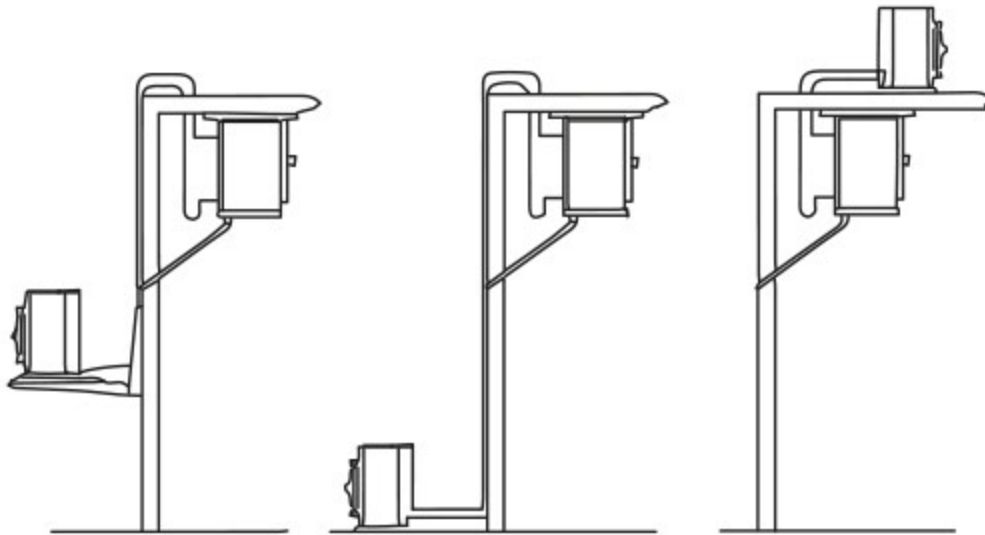

### ENDÜSTRİYEL TİP KONDANSER ÜNİTELERİ INDUSTRIAL TYPE CONDENSING UNITS

Endüstriyel Tip Kondanser Üniteleri orta ve yüksek kapasiteli soğutma ihtiyaçların olduğu endüstriyel tesisler için uygundur. Kompakt tasarımı sayesinde montaj ve bakımı kolaydır. Yüksek kapasiteli kompresörlerin kullanıldığı soğutma cihazlarımızda verimlilik üst seviyededir.

Industrial Type Condenser Units are suitable for medium and high capacity refrigeration industrial facilities. Installation and maintenance is easy through small compact design. Through high capacity compressors that are used in our cooling devices, productivity is high level.







## ÇİFT ÜFLEMELİ EVAPORATÖR DUAL DISCHARGE AIR COOLERS

Çift Üflemeli Soğuk Oda evaporatörlerimiz küçük ve orta soğutma ihtiyaçlarını karşılayabilmekte olup ticari ve endüstriyel soğutucu taleplerine cevap verebilmektedir.

Dual Discharge Air Coolers can meet the needs of small and medium cooling and can meet the demands of commercial and industrial refrigerants.

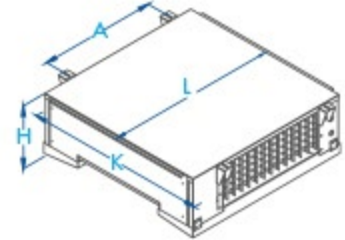
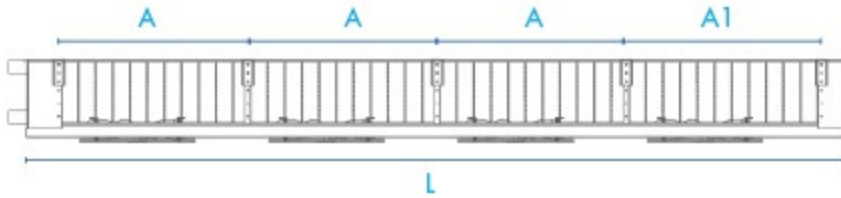

## KÖŞE TAVAN TİPİ EVAPORATÖRLER SLIM AIR COOLERS

Köşe Tavan Tipi Soğuk oda evaporatörlerimiz küçük ve orta soğutma ihtiyaçlarını karşılayabilmekte olup ticari ve endüstriyel soğutucu taleplerine cevap verebilmektedir.

Slim Air Coolers can be connected in small and medium classes and can meet the demands of commercial and industrial environments.

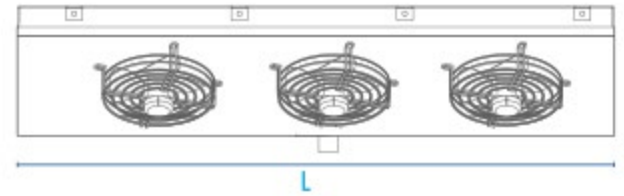

W

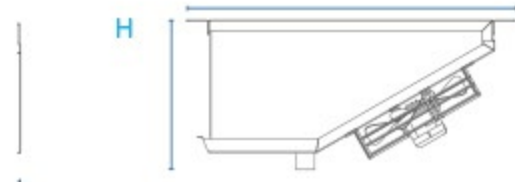

## STANDART EVAPORATÖRLER STANDART EVAPORATORS

Standart Evaporatörler soğuk Oda evaporatörlerimiz küçük ve orta soğutma ihtiyaçlarını karşılayabilmekte olup ticari ve endüstriyel soğutucu taleplerine cevap verilmektedir.

Dual Discharge Air Coolers can meet the needs of small and medium cooling and can meet the demands of commercial and industrial refrigerants.

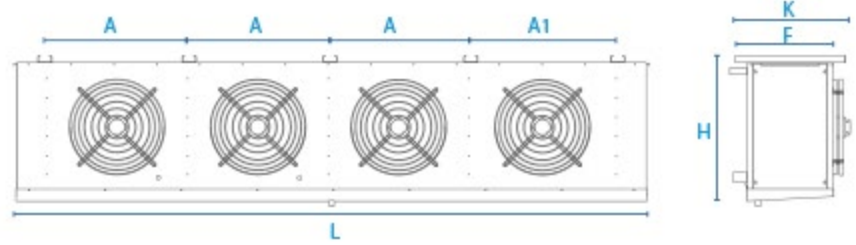
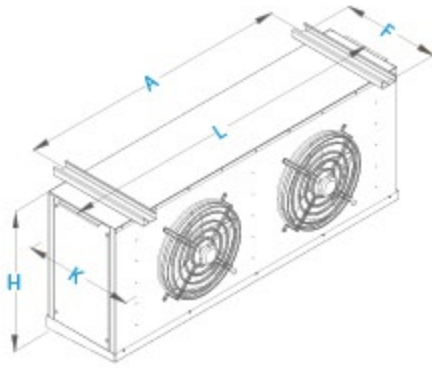

## ŞOK EVAPORATÖRLER BLAST FREEZING COOLER

Köşe Tavan Tipi Soğuk oda evaporatörlerimiz küçük ve orta soğutma ihtiyaçlarını karşılayabilmekte olup ticari ve endüstriyel soğutucu taleplerine cevap verebilmektedir.

Slim Air Coolers can be connected in small and medium classes and can meet the demands of commercial and industrial environments.

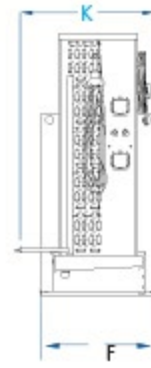
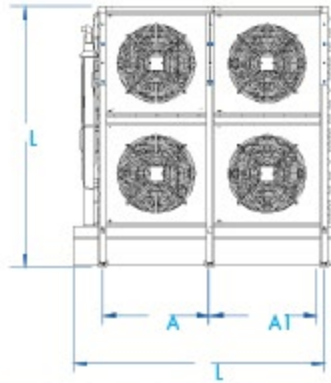
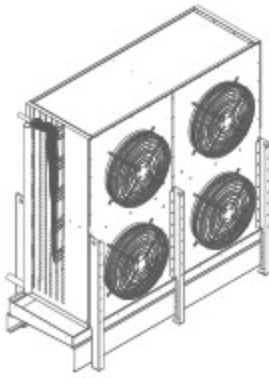

## EVAPORATÖRLER



# UYGULAMA ALANLARI

## Deniz Ürünleri İşleme ve Muhafaza Soğutma Sistemleri

## Seafood Processing and Storage Cooling Systems

Deniz ürünlerinde yüksek ürün kalitesini sağlamak için en kısa ürede soğutulması veya dondurulması kritik öneme sahiptir. ALBA Soğutma, balık işleme süreci boyunca, paketlenmeden depolamaya kadar, bütün soğutma ihtiyaçlarınıza uygun çözümler sunar.

Cooling the solution to produce the shortest to ensure high product quality in seafood or freezing is critical. ALBA Cooling System, along with fish processing, packaging and storage up to offer solutions suitable for all cooling requirements.



## Kanatlı Hayvan Kesimhaneleri Soğutma Sistemleri

## Poultry Slaughtering Cooling Systems

Kanatlı hayvan kesimhanelerinde ürünün mümkün olan en hızlı şekilde soğutulması ve muhafaza edilmesi en önemli husustur. ALBA Soğutma'nın sunduğu uzmanlık ve bilgi birikimi sayesinde, en yüksek hijyen standartlarını karşılayan, ihtiyacınız olan kapasitede, fonksiyonel bir soğuk zincirin ilk halkası oluşturulur.

Slaughtering the poultry product to be cooled as quickly as possible and maintain the most important consideration. ALBA Cooling System thanks to the accumulation of expertise and knowledge that provide cooling to meet the highest hygiene standards in the capacity you need, the first of a functional cold chain is created.



## Donmuş Gıda Üretim ve Depolama Soğutma Sistemleri

## Frozen Food Production and Storage Cooling Systems

Hem üreticiler hem de gıda dağıtıcıları, ürünlerin en uygun şekilde saklanması için depolama ve etkili soğutmanın, soğuk zincirin vazgeçilmez bir unsuru olduğunu farkındadır. ALBA Soğutma'nın uzman kadrosu her türlü donmuş gıda ve ürünler için, verimli, çevresel açıdan sürdürülebilirliği olan, uygun maliyetli soğutma projelerini işinize özel olarak tasarlamaktadırlar.

Both the manufacturer as well as food dispensers, storage and efficient cooling for the convenient storage of the products, is aware that an indispensable element of the cold chain. ALBA Cooling System experts team, of all kinds of frozen food products, efficient, sustainable from an environmental perspective, they are designed specifically to your cooling cost-effective business projects.



## Unlu Mamüller Soğutma Sistemleri

## Bakery Products Cooling Systems

ALBA Soğutma'nın 30 yıllık tecrübesi ve uzmanlığı; unlu mamül sektöründe enerji tasarrufu sağlayan, ekonomik ve çevreye duyarlı, yüksek performanslı, güvenilir, işletme sahibinin ihtiyaçlarını karşılayabilecek soğutma sistemleri tasarlamasını sağlamaktadır.

30 years of experience and expertise ALBA Cooling System; bakery industry in energy-saving, economical and environmentally friendly, high-performance, reliable, can meet the needs of the business owner is to provide the designing cooling systems.





## Et Ve Et Ürünleri Soğutma Sistemleri

## Meat And Meat Products Cooling Systems

Kesimden sonra, soğuk zincir ve bununla birlikte tüketiciye karşı sorumluluğumuz da başlar. Etlerin kaliteli ve lezzetlerini koruyabilmeleri için etkili şekilde soğutulması ve dondurulması gerekir. ALBA Soğutma'nın kurmuş olduğu et ve et ürünleri soğutma ve dondurma tesislerinde, sadece ürünlerin kalite ve lezzetlerinin korunduğundan emin olmazsınız; aynı zamanda sistemlerimiz, tüm hijyenik standartları karşılayarak en sağlam soğuk zincirin kurulmasını sağlar. Kullandığımız çevreci akışkanlar sayesinde de yatırımınızda enerji maliyetlerini düşürmenize yardımcı olur.

After cutting, cold chain and our responsibility towards the consumer, however, also starts. effectively cooling to preserve meat quality and flavor and should not be frozen. meat which was established by the ALBA Cooling System and meat products in refrigeration and freezing facilities, just make sure you do not protect the quality and taste of the products; Our system also provides the most robust cold chain was founded by meeting all hygienic standards. With environmentalists fluid we use helps to reduce energy costs in your investment.



## Süt Ve Süt Ürünleri Soğutma Sistemleri

## Milk And Milk Products Cooling Systems

Sütün soğutulması, kalitesinin korunması, bakteri üremesinin önlenmesi ve işleme sırasında doğabilecek olumsuz değişikliklerin önlenmesi için şarttır. ALBA Soğutma, soğutma alanında bir uzman olarak, sütü ve süt ürünlerini hızlı bir biçimde soğutmak ve saklama sırasında en uygun koşulları sağlamak için; verimli, güvenilir ve yenilikçi ekipman ve proje tasarımı ile işletmenize özel çözümler sunar.

Cooling the milk, maintain quality, it is essential to prevent adverse changes arising during the prevention and treatment of bacterial growth. ALBA Cooling System, as an expert in the cooling zone for cooling milk and milk products rapidly and to ensure optimal conditions during storage; efficient, reliable and your business with innovative equipment and project design offers customized solutions.



## Donmuş Gıda Üretim ve Depolama Soğutma Sistemleri

## Frozen Food Production and Storage Cooling Systems

Sarartma işlemi etilen gazının yardımıyla, sızdırmaz odalarda ısıcaklık, nem ve etilen konsantrasyonunun düzenlenmesiyle muz, mango, papaya gibi meyvelerin çoğunun olgunlaştırılması için kullanılır. Meyvelerin tatlılığını ve aromasını muhafaza etmesini sağlayarak, meyveye katma değer katar.

Ripening process with the aid of ethylene gas sealed rooms, humidity, and by regulating the ethylene concentration banana, mango, papaya is used to cure the majority of fruit like.



## Klimatik Test Odaları

## Climatic Test Chambers

Sıcaklık, nem ve hava hızının hassas olarak kontrol edildiği (PLC VE PC ile) özel olarak tasarlanmış odalardır. Test odaların duvar ve tavan bölümleri poliüretan dolgulu panellerle izole edilmektedir. Soğutma grubunun yanı sıra, nem kontrolü için nemlendirme cihazı ve nem alma cihazı kullanılmaktadır. Odaların içinde oluşturulan tam perforeli sac sistemi ile havanın içeriye üflenmesi homojen bir şekilde sağlanmaktadır. Mikroişlemcili dijital kumanda paneli ile, test odasının istenilen sıcaklık ve nem değerlerine getirilmesi için gerekli olan ısıtma, soğutma, nemlendirme işlemleri yapılmaktadır. Test odaları; kontrol dışı aşırı sıcaklık oluşması durumunda tüm sistemi durdurarak, alarm verecek şekilde dizayn edilmektedir.

Temperature, humidity and air velocity is precisely controlled (PLC and PC) are specially designed room. wall and ceiling portions of the test chamber is isolated with polyurethane filling panel. In addition to the chiller, humidifiers and dehumidifiers are used to control the moisture. Full perforated chamber formed in the inside of the air blowing system is provided with the sheet in a homogeneous manner. Microprocessor with digital control panel, which is required for the heating to the desired temperature and humidity of the test chamber, cooling and humidifying operation are performed. Test chambers; stopping the entire system out of control in the event of extreme temperatures, it is designed to give the alarm.





# PROJELER















# UYGULAMALAR

















